



SPW-Series Stretch Pallet Wrapper

Model: SPW-981HP, SPW-981LP

Distributed By:

Version 1.0
Last Updated: 10/10/19

SPW-981 Pallet Wrapper Manual

IMPORTANT - PLEASE READ THIS CAREFULLY

The development of a good safety program, that is rigidly enforced, is absolutely imperative when involved in the operation of industrial equipment. Our machinery is well designed and includes extremely important safety features. The part you the user play through proper installation and maintenance procedures is of far greater significance than our designs. Only properly trained individuals following rigidly enforced safety rules, as recommended by A.N.S.I. and O.S.H.A., should be allowed to operate these machines.

SPW-981 Pallet Wrapper Manual

TABLE OF CONTENTS

Preface

Warranty Notice	5
Warranty	6-7
Warranty Exceptions	8
Warnings	9-11
General Safety Regulations	12
Unpacking	13-14

Pallet Wrapper Section

Description	15
Specifications	16
Technical Data	17
Installation and basic set up	18-19
Plugging Machine In	20
Installation of film roll	21
Installation of Optional Loading Ramp	22
Leveling turntable base	23
Front control panel	24
Turning on machine	25
Set machine parameter	26-27
Set bottom count	28
Set top count	29
Set wrap height	30
Setting program memory	31
Setting height in CM or inches	31-32
How to enter different program settings	33-35
Setting special function calibration for height setting	36-38
How to operate in automatic mode	39
How to operate in manual mode	39-40
Getting started	41-43

SPW-981 Pallet Wrapper Manual

Adjustments

Mechanical Brake Stretch	44
Film Roll Carriage Down Stroke Limit	45

Troubleshooting

Machine does not start	46-48
Machine in Emergency Stop Mode	49
Turntable will not turn	50
Film Carriage will not rise	51
Film is not Stretching	52

Maintenance

General Maintenance Requirements	53
Checking turntable chain tension	54-56
Replacing turntable drive chain	57
Replacing the turntable support rollers	58-59
Replacing the film carriage lift belt	60-61

Exploded view drawings with parts listings	62-69
---	-------

Spare Parts List	70
-------------------------	----

Electrical Schematic	71
-----------------------------	----

SPW-981 Pallet Wrapper Manual

IMPORTANT WARRANTY NOTICES**OPERATING AND MAINTENANCE MANUAL**

The operating and maintenance manual has been carefully prepared to provide the user with all the information needed to properly install, operate, and maintain your Sealer Sales equipment.

Please read this manual carefully and refer to it for information on the care and use of your Sealer Sales equipment. It is recommended that additional copies be ordered for use by production, maintenance, and supervisory personnel. Although the design of this equipment incorporates safeguards to protect personnel, care should be used in operating, adjusting, and servicing.

Attention is directed to the warranty which accompanies all your Sealer Sales equipment. The terms and conditions of this warranty apply only to unmodified units. Any unauthorized modifications to the equipment automatically voids this warranty.

SPW-981 Pallet Wrapper Manual

Sealer Sales

WARRANTY

Sealer Sales, Inc. warrants each new product manufactured to be free from defects in material and workmanship for a period of 1 year from date of shipment by Sealer Sales.

Not covered by this warranty is normal wear of components such as, but not limited to; belts, chains, fuses, bulbs, rollers etc. or misuse or abuse of the machine or any components thereof. As well, parts returned without the prescribed paperwork will not be covered by this warranty. Labor to remove or repair any component is also not covered by this warranty. Damage in transport is the responsibility of the carrier and is not covered under our warranty. This warranty is not transferable with any subsequent resale.

Defective parts under warranty must be returned to Sealer Sales freight prepaid. Sealer Sales's sole obligation and purchaser's sole remedy in the event of a warranty dispute shall be, at Sealer Sales's option, to repair or replace the part in question. Labor incurred in removing or installing the defective part is not covered by this warranty. Prior to returning any parts for any reason, contact Sealer Sales for a Return Authorization Number. This number must accompany all returns.

This warranty shall not apply if equipment has been tampered with, misused, improperly installed, altered, or has received damage due to abuse, carelessness, accident or failure to follow recommended regular maintenance procedures or has been serviced by someone other than a duly authorized factory representative without the express written consent of Sealer Sales, Inc.

SPW-981 Pallet Wrapper Manual

This warranty is in lieu of all other warranties, expressed or implied, including but not limited to warranties of merchantability and fitness for a particular purpose, non-infringement or any other matter.

Sealer Sales shall have no liability to any person for direct, indirect, incidental or consequential damages or delay resulting from any defect negligence, or tort and customer hereby waives for itself any and all claims for punitive damages and all claims of negligence of strict liability or both. In no event shall our liability exceed the purchase price of the product which was actually paid.

Sealer Sales reserves the right to make changes, additions, or improvements to our products with no obligation to make such changes in any previously shipped product covered by this warranty.

Sealer Sales shall not be held liable for any damages arising out of or in connection with the operation of the equipment should customer or its agent fail to maintain equipment in safe operating condition. This warranty shall become unenforceable if and to the extent the customer or its agents remove, disconnect, or otherwise render useless any safety device and or parts designed or affixed by us or fails to maintain and service equipment in a manner as advised.

Sealer Sales provides a 2 year warranty on parts, excluding shipping or freight costs for replacement parts. All warranty parts are shipped F.O.B. Rancho Cucamonga, California.

SPW-981 Pallet Wrapper Manual

WARRANTY EXCEPTIONS

The following parts are an exception to the general warranty list on page 9. Each part listed below shall carry a 30-day warranty unless designated otherwise.

SPW-981

1. Fuses



SPW-981 Pallet Wrapper Manual

WARNINGS

Every effort has been taken to ensure your safety while operating this machine; however, there still remain certain risks. Do not allow this machine to be operated before informing all personnel of the following warnings.

WARNING.....

Do not tamper with the electrical wiring. Only use a licensed electrician for maintenance. Always disconnect the electrical power before attempting any maintenance to all electrical and/or moving parts.

WARNING.....

In order to prevent injury to personnel and/or machinery
DO NOT INCREASE SETTINGS OR RATINGS ON EITHER ELECTRICAL OR MECHANICAL OVERLOAD SAFETY DEVICES.

WARNING.....

KEEP HANDS AWAY FROM MOVING CONVEYORS AND ASSEMBLIES. Conveyor belts that have become worn or frayed are capable of being hazardous. They should be replaced promptly.

WARNING.....

NEVER OPERATE THIS OR ANY MOVING EQUIPMENT WITHOUT ALL COVERS AND GUARDS IN PLACE. The internal mechanism of most packaging machinery contains numerous shear, pinch, and inrunning nip points, many of which are capable of causing severe injury and/or permanent disfigurement.

SPW-981 Pallet Wrapper Manual

WARNING.....

To minimize the potential for personnel injury, always be sure that machine operators and others working on the machinery are properly trained in the correct usage of the equipment and properly instructed regarding the safety procedures for operation.

WARNING.....

Heat sealing arms and sealing jaws on packaging machinery can become very warm after a period of use. KEEP HANDS AWAY WHILE IN OPERATION AND USE CAUTION IF THE MACHINE HAS BEEN RUNNING RECENTLY.

WARNING.....

ANY MODIFICATIONS TO EITHER THE ELECTRICAL CIRCUITRY OR THE MECHANICAL ASSEMBLIES OF THE MACHINERY WILL VOID ANY WARRANTIES ASSOCIATED WITH THIS EQUIPMENT. Such modifications may introduce hazards that would not otherwise be associated with this machinery. Sealer Sales will not be responsible for any consequences resulting from such unauthorized modifications.

WARNING.....

The use of certain types of plastic films in sealing and/or shrinking equipment may result in the release of HAZARDOUS FUMES due to the degradation of the film at high temperatures. Before using any plastic film in this equipment, the manufacturer or supplier of the film should be contacted for specific information concerning the potential release of hazardous fumes. ADEQUATE VENTILATION MUST BE PROVIDED AT ALL TIMES.

SPW-981 Pallet Wrapper Manual

WARNING.....

It is important that the machine operator turn off the Main Power Switch when he/she has finished operating the unit.

SPW-981 Pallet Wrapper Manual

General Safety Regulations

Before using the machine or carrying out maintenance operations read the following instructions very carefully:

Before

1. Read the instructions about how to set up the machine
2. Check all the safety guards on the machine and immediately replace any worn or broken parts with original spares.
3. Make sure that no tools or other objects have been left lying on the machine and that the machine itself is perfectly clean.
4. Read the maintenance and spare parts very carefully.
5. Read all the labels and plates applied to the machine.

During

1. Do not wear clothing that could get tangled up in the moving parts of the machine.
2. Do not put the hands or any kind of object inside the field of operation of the machine
3. Do not load the machine with boxes heavier than those recommended by the manufacturer.

After

1. Always stop the electric motor by pressing the red button on the switch
 2. Switch off the electric power.
-
-

SPW-981 Pallet Wrapper Manual

UNPACKING**THOROUGHLY INSPECT EQUIPMENT UPON ARRIVAL.**

If goods are received short or in a damaged condition, it is important that you notify the carrier's driver **before he leaves your company** and **insist** on a notation of the loss or damage across the face of the freight bill. Unless this is done, no claim can be enforced against the transportation company.

If concealed loss or damage is discovered, notify the carrier at once and insist on an inspection. This is absolutely necessary! A concealed damage report must be made no later than ten (10) days from the date the shipment was delivered. Unless you do this, the carrier will not consider any claim for loss or damage. The carrier's agent will then make an inspection and grant a concealed damage notation. If you give the transportation company a clear receipt for the goods that have been damaged or lost in transit, you do so at your own risk and expense.

All claims must be filed within 10 Days of delivery date or carrier will not accept them.

Sealer Sales is willing to assist in every possible manner to collect claims for loss or damage; however, this does not hold Sealer Sales responsible for collection on claims or replacement of material.

SPW-981 Pallet Wrapper Manual

Unpacking

* Picture shown with optional ramp



Your model SPW-981 is enclosed in a wooden crate for protection. If your machine does not arrive in good condition, write on shipping paperwork that concealed damage may have occurred. You must write on bill of lading that concealed damage may have occurred. **If you do not – The Freight companies will not pay any damage claims filed due to clear signed bill of lading.**

Remove stretch film protective wrap and remove pallet wrapper from crate.

* Pallet Wrapper is fork lift portable and has fork channel at base of frame. You may use these channels to remove the Pallet Wrapper with fork lift.

SPW-981 Pallet Wrapper Manual

Description

The model SPW-981 is a versatile, reliable and economical pallet stretch wrapping machine designed to accommodate a large variety of pallet sizes. Using modern technology the model SPW-981 will apply stretch film to a pallet load. This inexpensive system offers a high degree of protection for any pallet load.

Operation

The operation of the model SPW-981 pallet wrapper comprises 4 easy steps

1. Operator places pallet load on revolving turntable by means of forklift or pallet jack (if optional ramp is used)
 2. Operator attaches stretch film to turntable base
 3. Press "start" cycle for automatic operation
 4. Cut film from pallet load at completion of work cycle.
-

SPW-981 Pallet Wrapper Manual

Specifications**Roll Dimensions**

The machine is capable of using different types of stretch film with the following dimensions:

- A: Internal diameter of roll 3" (76.2mm)
- B: External diameter of roll 12" (300mm)
- C: Height of roll: 20"
- D: Thickness of film: STD 80gauge
*Other film thickness may be used
- E: Weight of roll: 40lbs max

In order to obtain the best results while using your machine we recommend using a good quality stretch film.

Pallet Dimensions

The model SPW-981 can generally wrap pallets with the overall dimensions listed below

- Maximum Length: 48" (1,200mm)
- Maximum Width: 48" (1,200mm)
- Maximum Height: 85" (2,150mm)

Pallet Weight

Maximum recommended pallet weight load is 3,000lbs (1,400kg)

SPW-981 Pallet Wrapper Manual

Technical Data

Machine Weight	1,000lbs (4.75kg)
Shipping Weight-Approximate	1,400lbs (640kg)
Crated Dimensions	129" L x 63" W x 29" H (3,277mm) x (1,600mm) x (737mm)
Power Requirements	110volt/15amp
Recommended Operating Temperatures	Min 40 f / Max 104 f +5 / +40 c
Turntable Rotation Speed	10RPM

SPW-981 Pallet Wrapper Manual

Installation & Set Up



Fork lift
channels

Use the two fork channels mounted on each side of base to remove Pallet Wrapper from crate and place on floor in desired position near electrical outlet.



The mast is heavy- Take precaution when lifting mast.

SPW-981 Pallet Wrapper Manual



Take care when raising mast so you do not pinch cables when lowering mast.



Clear all cables before lowering mast.



Once mast is raised, use the 10mm bolts provided and mount the mast to base. Mounting hardware is provided 3 bolts at back of mast and 3 bolts in front.

SPW-981 Pallet Wrapper Manual

Plug Machine In



Machine comes complete with power cord and 110volt plug.
***Make sure to use a dedicated line-** Do not run any other equipment on same power line.

Before plugging in machine make sure main power switch is in off position.

Plug into regular 110volt power outlet.
Make sure the voltage supplied to the machine is 110 volt.

SPW-981 Pallet Wrapper Manual

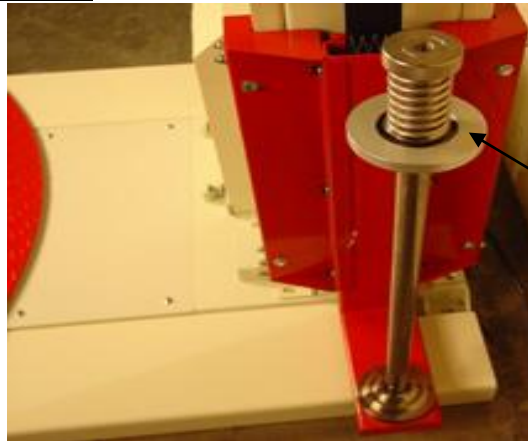
Installing Film Roll

Tension spring
assembly

Remove film tension spring assembly by turning counter clock wise.



Load film roll and tighten spring tension assembly. Whenever it is necessary to wrap the film more tightly around the pallet, thus saving material, the film roll unwinding can be varied by turning the hand wheel which by means of the clutch below it, brakes the film and stretches it more tightly.

*Special care should be taken when using rolls of stretch film with single sided cling. Make sure the roll is facing the right direction, so that the cling or sticky side of the film is in contact with the pallet load.

SPW-981 Pallet Wrapper Manual

Install Loading Ramp



Install custom bolt to base frame in threaded holes provided in frame. Ramp can be mounted from three sides. Bolt holes are provided on all three sides. Ramp requires on two bolts to secure ramp.



Ramp is very heavy, use two people to lower ramp over bolts. Align slots in ramp with slot in bolt. Lower ramp into position.

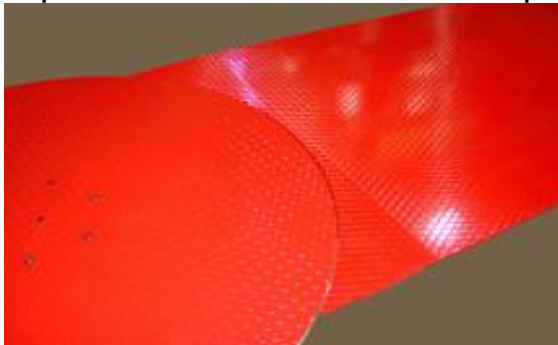

Ramp should fit evenly and snug against frame.

SPW-981 Pallet Wrapper Manual

Leveling Turntable Base



Adjust the 4 leveling bolts on base frame so turntable base sits evenly on floor.

SPW-981 Pallet Wrapper Manual

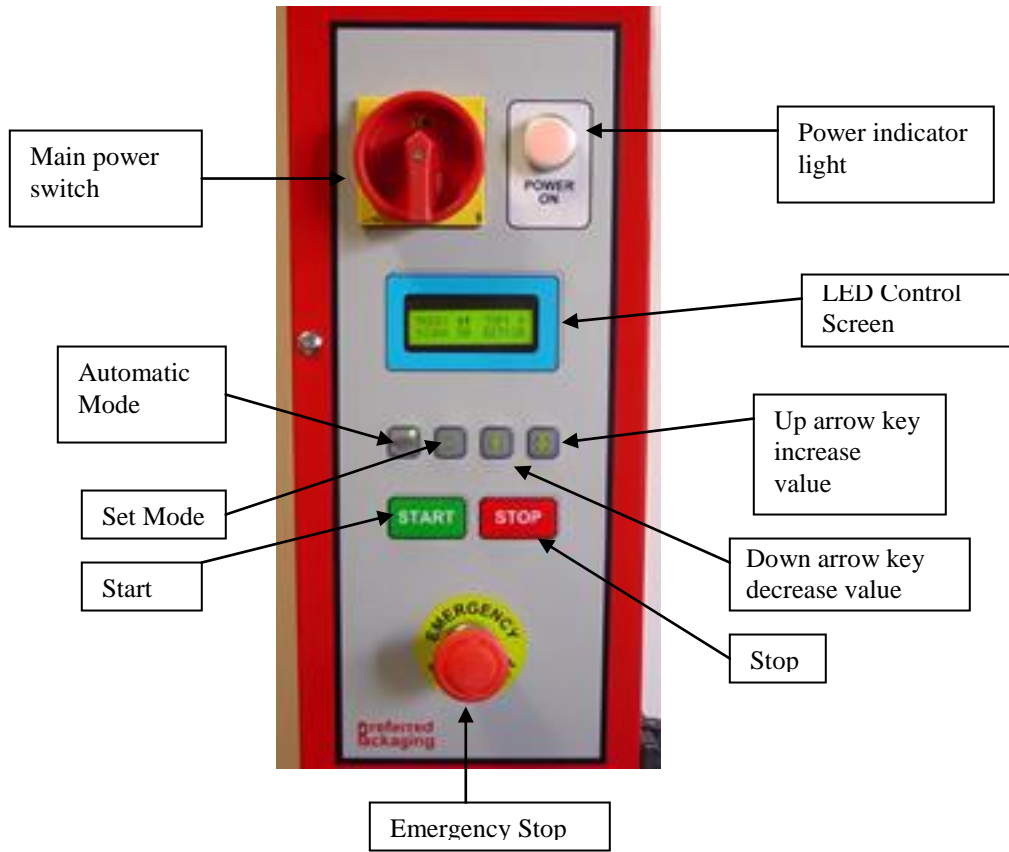

Front Control Panel

SPW-981 Pallet Wrapper Manual

Turning on Machine



Turn power switch to **on** position

SPW-981 Pallet Wrapper Manual

Set Machine Parameters



When you turn on your machine the model number will temporarily be displayed.



The front control LED will now display what the current machine parameters are set at.

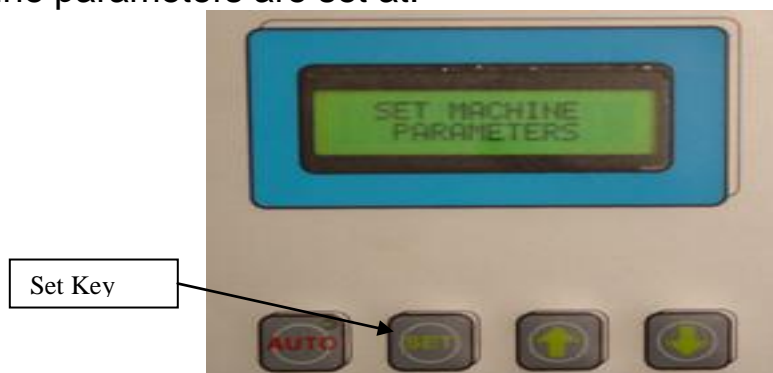

Press set key once and display will show **“set machine parameters”**.

SPW-981 Pallet Wrapper Manual

Set Machine Parameters



Press Set and select mode will appear ↓↑ mode indicates pallet wrapper will start at bottom of cycle raise to selected height setting then return to bottom of cycle.

SPW-981 Pallet Wrapper Manual

Set Bottom Count



Press and "**set bottom count**" will appear. The number on the display tells you how many times the turntable will cycle before it starts upward.



To change wrap count simply press arrow key up to increase bottom wrap count or down arrow key to decrease wrap count.

SPW-981 Pallet Wrapper Manual

Set Top Count



Press top wrap count will appear.



To change top wrap count simply press arrow key up to increase or down to decrease top wrap count.

SPW-981 Pallet Wrapper Manual

Set Wrap Height



Press and wrap height will appear use arrow keys up or down to increase or decrease wrap height. Display indicates what height film carriage will rise to.

*Note: If you are wrapping different height pallet loads you will need to adjust the height setting to fit the pallet load.



Press up or down arrow keys to increase or decrease film carriage height.

***The film carriage travels at a fixed speed and is not adjustable.**

SPW-981 Pallet Wrapper Manual

Setting Program Memory

Your model SPW-981 is equipped with a 10 program memory function which will allow you to pre-set up to 10 different program settings for different pallet requirements.

Setting Unit of Measure=or inches



From main display menu press auto key until light goes out.



Press Set key display will show "set" machine parameters".



Press arrow key to advance to next screen "select memory" 1-10.



From "select memory" 1-10 screen press up arrow key to reach next screen.

SPW-981 Pallet Wrapper Manual



From "set memory parameters"
Press up arrow key to set unit of
Measure.



Allows you to set the
measurements in cm or inches.



Use the up or down keys to set unit of measure form cm to inches
when finished press will take you back to the main menu.

SPW-981 Pallet Wrapper Manual

Entering Different Program Settings



Press auto until light goes out-you are now in manual mode.



Press Set key to advance to next screen.



Press arrow key up to advance to next screen.



Press arrow key up to advance to next screen.

SPW-981 Pallet Wrapper Manual



Press key to access Machine parameters.



Choose operated mode up and down cycle or up only/ down only. Press when complete.



Use arrow key to set# of bottom wrap counts.



Use arrow key to choose # of top wrap counts.

SPW-981 Pallet Wrapper Manual



Select wrap height for this program.



“Set memory” will appear this screen allows you to choose which program you would like the information stored in. You can choose from 1-10. report this process to program other parameters for different pallet wrapping requirements.



Press auto key again and light will go on-machine is now in automatic mode. Simply press start to activate machine.

SPW-981 Pallet Wrapper Manual

Setting Special Function Calibration-For Height Setting

1. Special function calibration is factory set
2. This function should only be used if you are using 50hz power supply (or).
3. If the height setting on the control panel is set at a specific height say for example (48") and the film carriage will only rise (40") the machine is out of calibration and should be reset using the following instructions.



Press auto key until light goes Out-you may now operate Machine in manual mode.

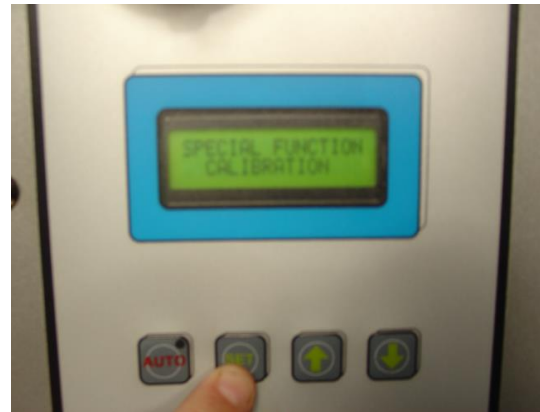

Press Set key and hold for 2-3 seconds and display will show "special function calibration".

SPW-981 Pallet Wrapper Manual



Press the start key. The film Carriage will rise to the top of the Mast and stop.



Display will show special function running until film carriage reaches top of mast.



Film carriage at top of mast.

SPW-981 Pallet Wrapper Manual

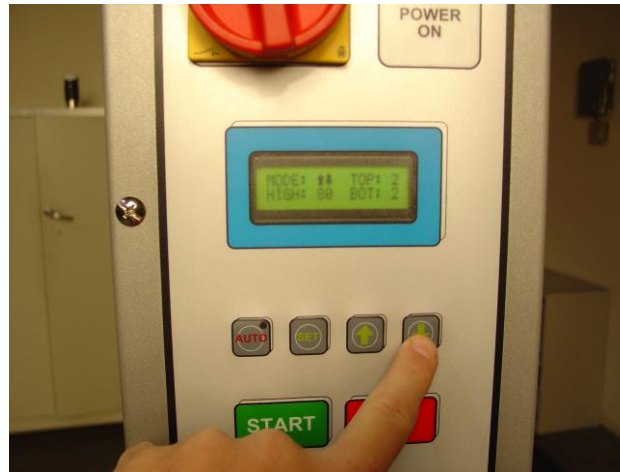

Once film carriage reaches top display will start at home. Press down arrow key to return film carriage to bottom of mast.

*This calibration feature set the time required for the film carriage to reach the top of the mast. This time it will then be calibrated to the settings on the control panel for the required height setting.

SPW-981 Pallet Wrapper Manual

Operated in Automatic Mode



With machine in mode press start and machine will automatically wrap at preset parameters.

Operate in Manual Mode



To run machine in manual mode press key until light goes out.



Press to run turntable in manual mode. Turntable will run as long as start key is depressed. Once released the turntable will stop turning.

SPW-981 Pallet Wrapper Manual



To operate film carriage in manual mode make sure auto light is not on and press arrow keys up or down to raise or lower film carriage.

SPW-981 Pallet Wrapper Manual

Getting Started



Turn power switch to "on" position.



Place pallet load into turntable and try to center pallet load evenly on turntable base.



Pull several feet of film off the roll enough to attach to turntable. Tighten tension knob to establish pre-stretch tension in film.

SPW-981 Pallet Wrapper Manual



With tension knob fully tightened threads will be exposed 1 to 1.5" a fully tightened knob will provide approximately 100 to 150% film pre-stretch. We recommend starting at 50% depending on the quality of stretch film used.



Attach film tale to metal tab on turntable base.

SPW-981 Pallet Wrapper Manual



Press the auto mode button.



Press the start button. The machine stops automatically at the end of the cycle.

Cut the stretch film by hand and press excess film against pallet load to attach.

Remove the pallet load via fork lift or pallet jack if ramp is used. The cycle can be interrupted at any time by pressing the emergency push button stop switch located at the bottom of the front control panel.

The machine is now ready to repeat the wrap cycle as per the pre-set values. The number of top or bottom wrap counts or carriage height can be changed at any time.

SPW-981 Pallet Wrapper Manual

Adjustments-Mechanical Brake Stretch

When tension control spring is loose the pallet wrap will apply film loosely to the load.



By turning the tension spring clockwise to tighten film roll the film will be stretched and applied tightly to the pallet load. At maximum tension you will stretch film approximately 125 to 150%.

SPW-981 Pallet Wrapper Manual

Adjustment of Film Carriage Down Stroke Limit

The down stock limit switch should be set as low as possible without hitting the machine frame. This will insure the stretch film will grab pallet load and wooden pallet together to secure load.

SPW-981 Pallet Wrapper Manual

Troubleshooting

Machine will not start



1. Check to make sure the machine is plugged into 110volt power Source. Check for voltage present in line.

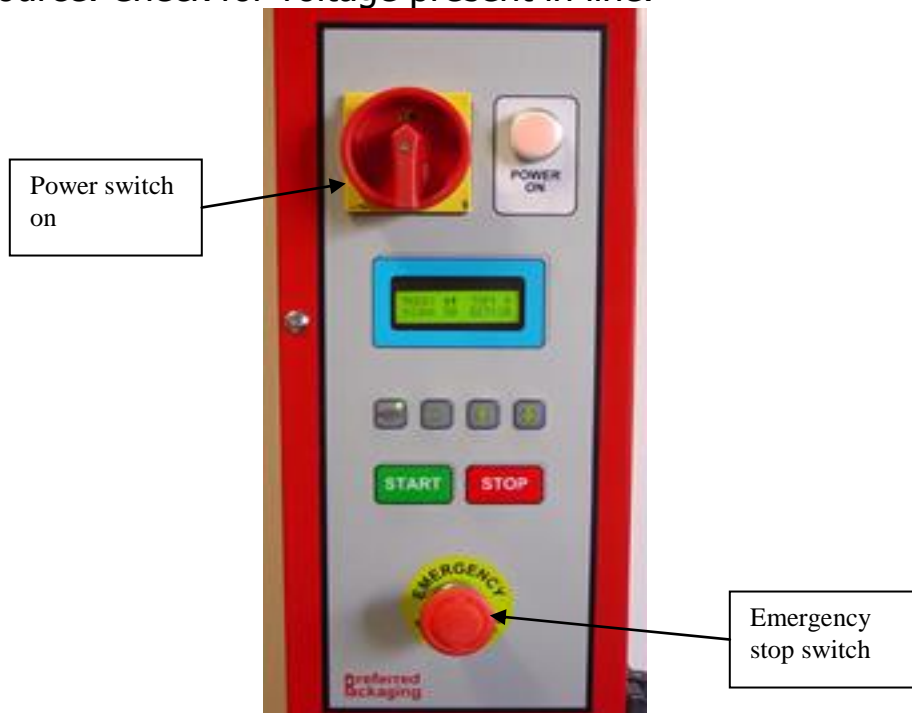

- A. Make sure main power switch is in "on" position.
 - B. Make sure emergency stop switch is not depressed and activated. Turn counter clockwise to disengage.
-

SPW-981 Pallet Wrapper Manual



Make sure you have put machine in mode. **Light will be on.**



Make sure to press button to activate machine.

SPW-981 Pallet Wrapper Manual



Remove the 3 screws holding front control panel closed.



Test fuse F-1 and F-2 for continuity. Replace if required.

SPW-981 Pallet Wrapper Manual

Machine in Emergency Stop Mode



Turn emergency stop switch counter clock wise to disengage.

SPW-981 Pallet Wrapper Manual

Turntable will not turn

1. Check electrical connections



2. Check contactor and replace if necessary.



3. Check connections to turntable drive motor. Test motor – Replace if necessary.
-

SPW-981 Pallet Wrapper Manual

Film Carriage will not rise



Remove turntable top plate.



Check micro switch- make sure switch is hitting activation plate mounted to sprocket. If switch is not hitting plate it will not count the resolutions. Adjust switch outward until it is activated by plate.

SPW-981 Pallet Wrapper Manual

Film will not stretch



Tighten spring tension control



Clutch disk wear occurred – Replace if necessary.

SPW-981 Pallet Wrapper Manual

Maintenance

1. No special preventative maintenance operations are required, but it is a good habit to check regularly the condition of the main machine parts, carriage belt, turntable drive chain, etc.
 2. Always replace worn out parts with original spare parts to prevent inefficiency and potential damage to machine.
 3. All maintenance operations should be carried out by personnel in charge of mechanical maintenance.
-

SPW-981 Pallet Wrapper Manual

Maintenance

A. Check drive chain tension-replace drive chain



1. Remove the 4 screws that hold the chain guard in place.



2. Remove the 6 screws holding turntable top in place and Slide top plate off base.



3. Turntable chain is now fully accessible.
-

SPW-981 Pallet Wrapper Manual

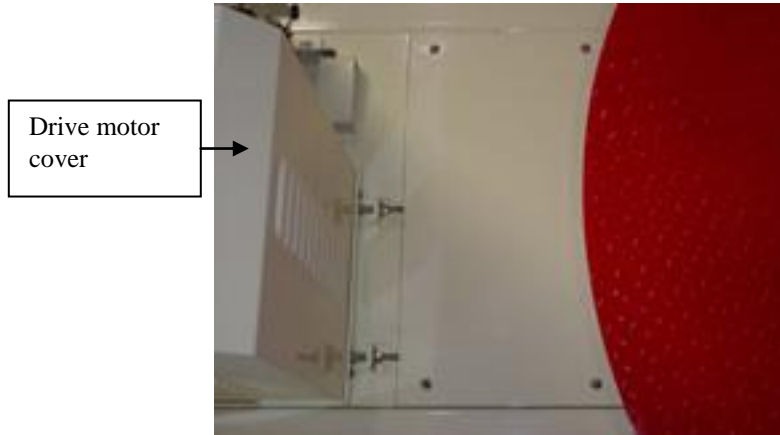

Loosen bolts and remove turntable drive motor cover.



Loosen motor adjustment plate bolts.

SPW-981 Pallet Wrapper Manual



6. Tighten chain tension adjustment bolts.



7. Adjust chain tension so chain just touches nylon support.
-

SPW-981 Pallet Wrapper Manual

Replace Drive Chain



1. To remove chain first follow steps 1-4 in previous section to loosen motor mounting bolts.



2. Loosen adjustment bolts completely and slide chain from sprocket.
-

SPW-981 Pallet Wrapper Manual

Replace Turntable Support Rollers



Remove the 6 turntable screws holding the top in place.



These are 14 sets of rollers – replace as needed.



Place screw driver under roller and gently pry roller upward.

SPW-981 Pallet Wrapper Manual



Remove complete roller assembly and replace.

SPW-981 Pallet Wrapper Manual

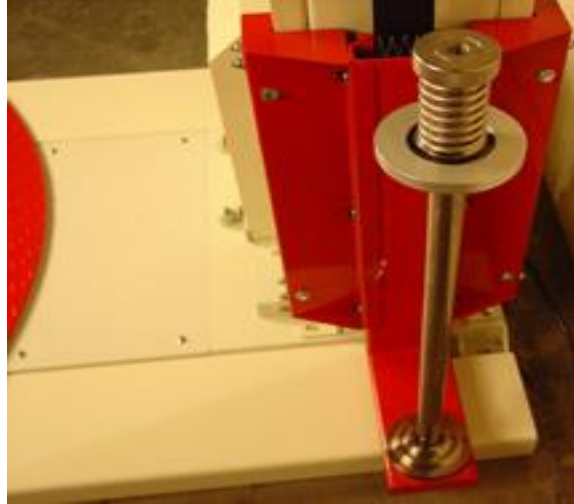
Replace Film Carriage Belt

Remove 6 bolts holding roll shaft. This will allow access to lower belt attachment. Remove clip pins holding shaft in place then remove belt.



Remove top belt cover.

SPW-981 Pallet Wrapper Manual



To unwind belt at top, place block under film carriage to lift up so it does not touch bottom switch. In manual mode activate film carriage down. This should unwind belt enough to access the screws holding the upper belt in place.

SPW-981 Pallet Wrapper Manual

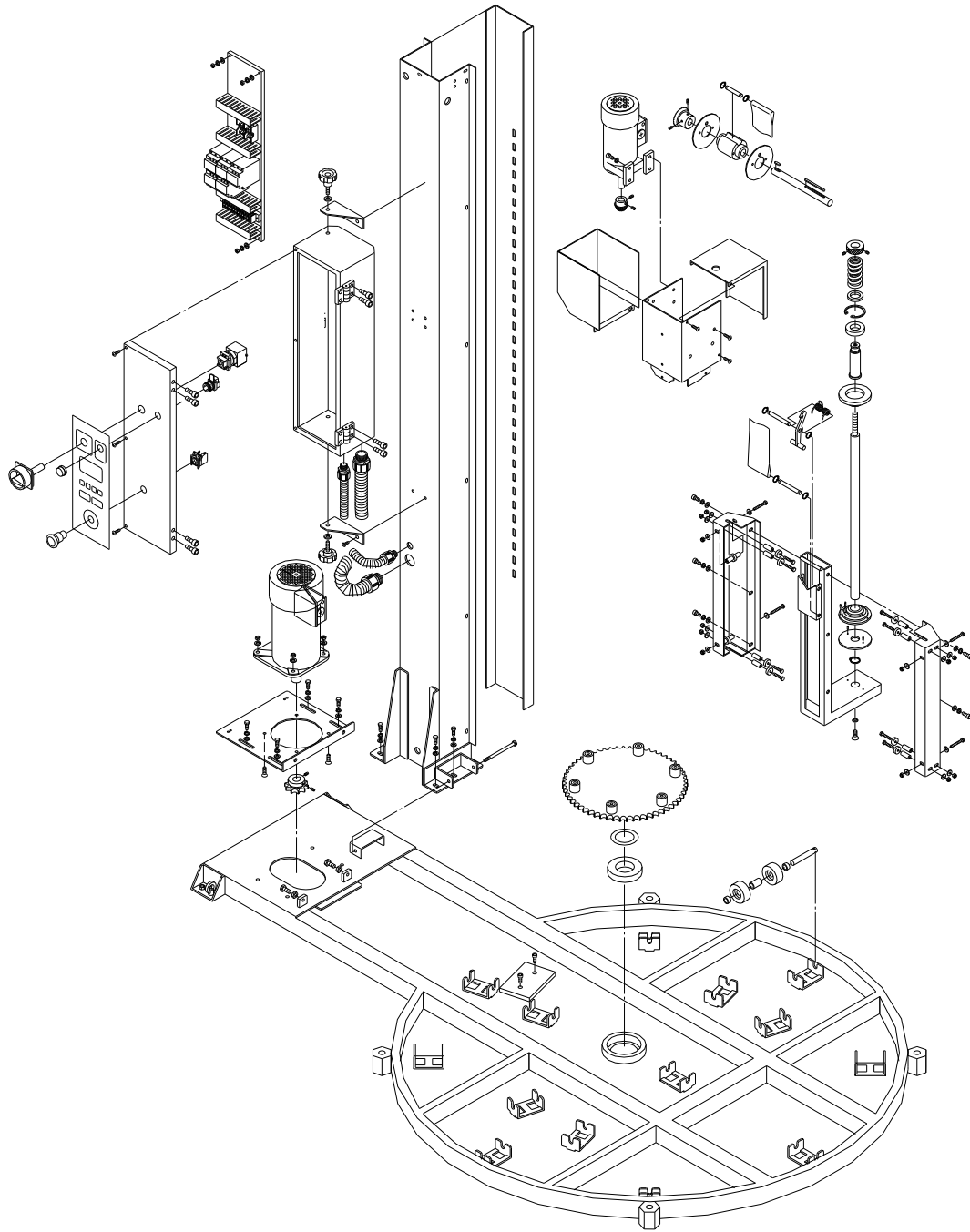

SPW-981 Pallet Wrapper Manual

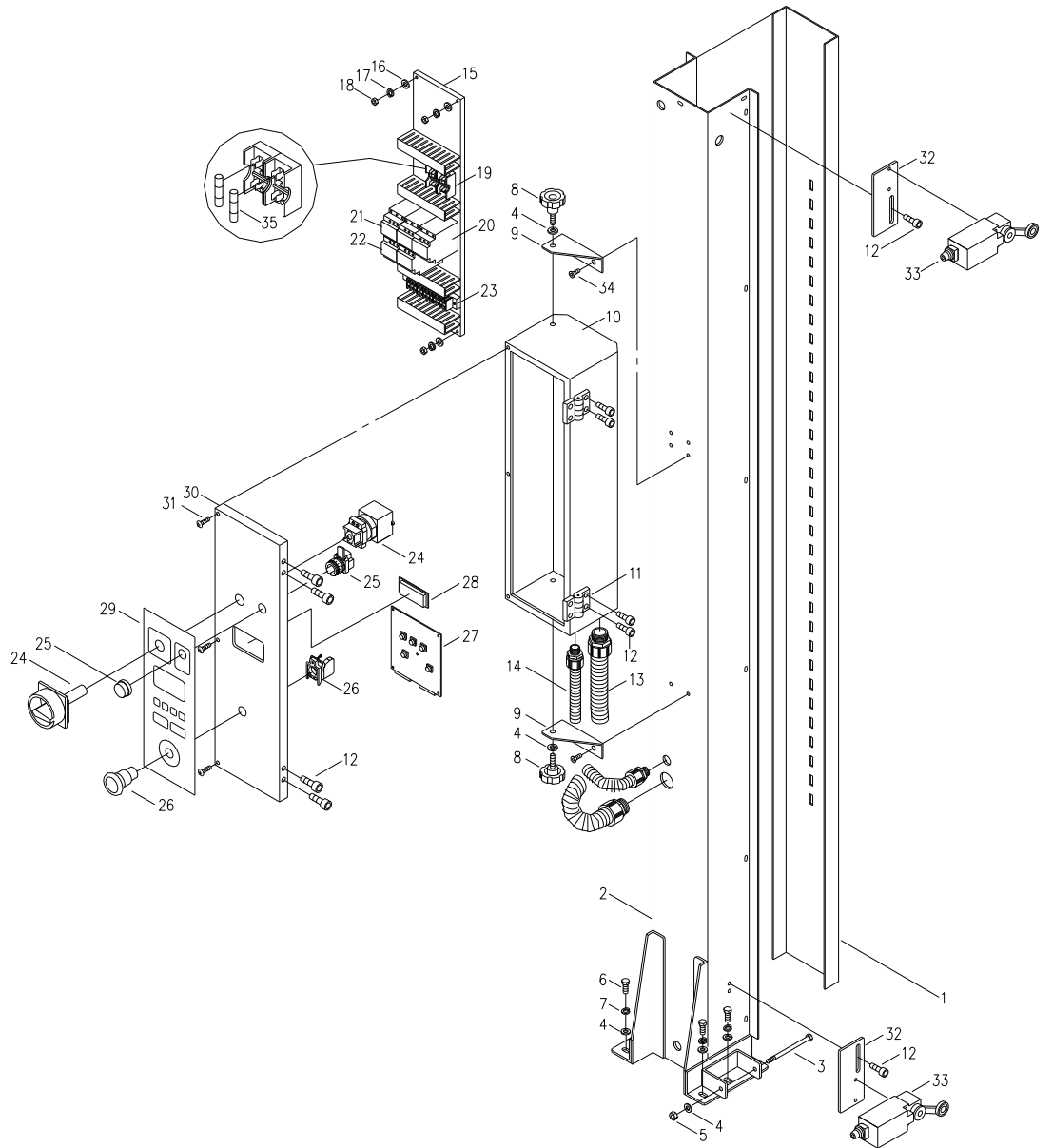

SPW-981 Pallet Wrapper Manual

Pos.	Part #	Qty	Description
1	B10049	1	Tower cover
2	B10050	1	Tower base
3	S01-08120	1	Hexagon bolt, M8x120
4	S15-0802	5	Plain washer, M8
5	S12-0808	1	Hexagon nut, M8
6	S01-0820	4	Hexagon bolt, M8x20
7	S16-0800	4	Spring washer, M8
8	B10051	2	Plastic knob screw
9	B10052	2	Control box bracket
10	B10053	1	Control box
11	B10054	2	Door hinge
12	S02-0612	8	Hex socket bolt, M6x12
13	B10055	1	Wire pipe, large
14	B10056	1	Wire pipe, small
15	B10057	1	Control box base
16	S15-0601	4	Plain washer, M6
17	S16-0600	4	Spring washer, M6
18	S12-0605	4	Hexagon nut, M6
19	E33400	2	Fuse box
20	E11000	1	Magnet contactor
21	E11100	2	Magnet contactor
22	E15000	2	Overload contactor
23	E30800	13	Terminal block
24	E24500	1	Power switch
25	E26500	1	Pilot lamp
26	E23100	1	Emergency stop switch
27	E05100	1	Control board, 110V
28	E05200	1	LCD display board
29	B10058	1	Control panel sticker
30	B10059	1	Control box front door
31	S08-0630	3	Truss head machine screw, M6x30
32	B10060	2	Limiter switch bracket
33	E29000	2	Limiter switch
34	S04-0612	4	Flat socket head screw, M6x12
35	E41100	2	Fuse

SPW-981 Pallet Wrapper Manual

Pos.	Part #	Qty	Description
1	E63000	1	Up-down gear motor, 110V/ 60Hz
2	S02-0820	4	Hex socket bolt, M8x20
3	S16-0800	4	Spring washer, M8
4	B10002	1	Tapered gear
5	S09-0610	4	Hex socket set screw, M6x10
6	B10003	1	Tapered gear
7	B10004	2	Guide plate
8	B10005	1	Belt pulley
9	B10006	1	Belt pulley shaft
10	S24-1000	2	External circlip, S10
11	B10007	1	Belt shaft
12	B10008	1	Belt
13	S21-060622	1	Round end key, 6x6x22
14	S21-060690	1	Round end key, 6x6x90
15	B10009	1	Top cover
16	S08-0610	6	Truss head machine screw, M6x10
17	B10010	1	Motor cover
18	B10011	1	Motor base
19	B10012	1	Knurled knob
20	B10013	1	Spring
21	B10014	1	Spacer
22	S23-3200	1	Internal circlip, S32
23	S56006	1	Ball bearing 6006zz
24	B10015	1	Shaft
25	B10016	1	Upper core holder
26	B10017	1	Core shaft
27	B10018	1	Lower core holder
28	B10019	1	Brake plate
29	S24-2500	1	External circlip, S25
30	B10030	1	Film carriage
31	S24-1000	1	Cone washer, M10
32	S04-1020	1	Flat socket head screw, M10x20
33	B10032	1	Spring
34	B10033	1	Shaft
35	B10034	1	Safety latch

SPW-981 Pallet Wrapper Manual

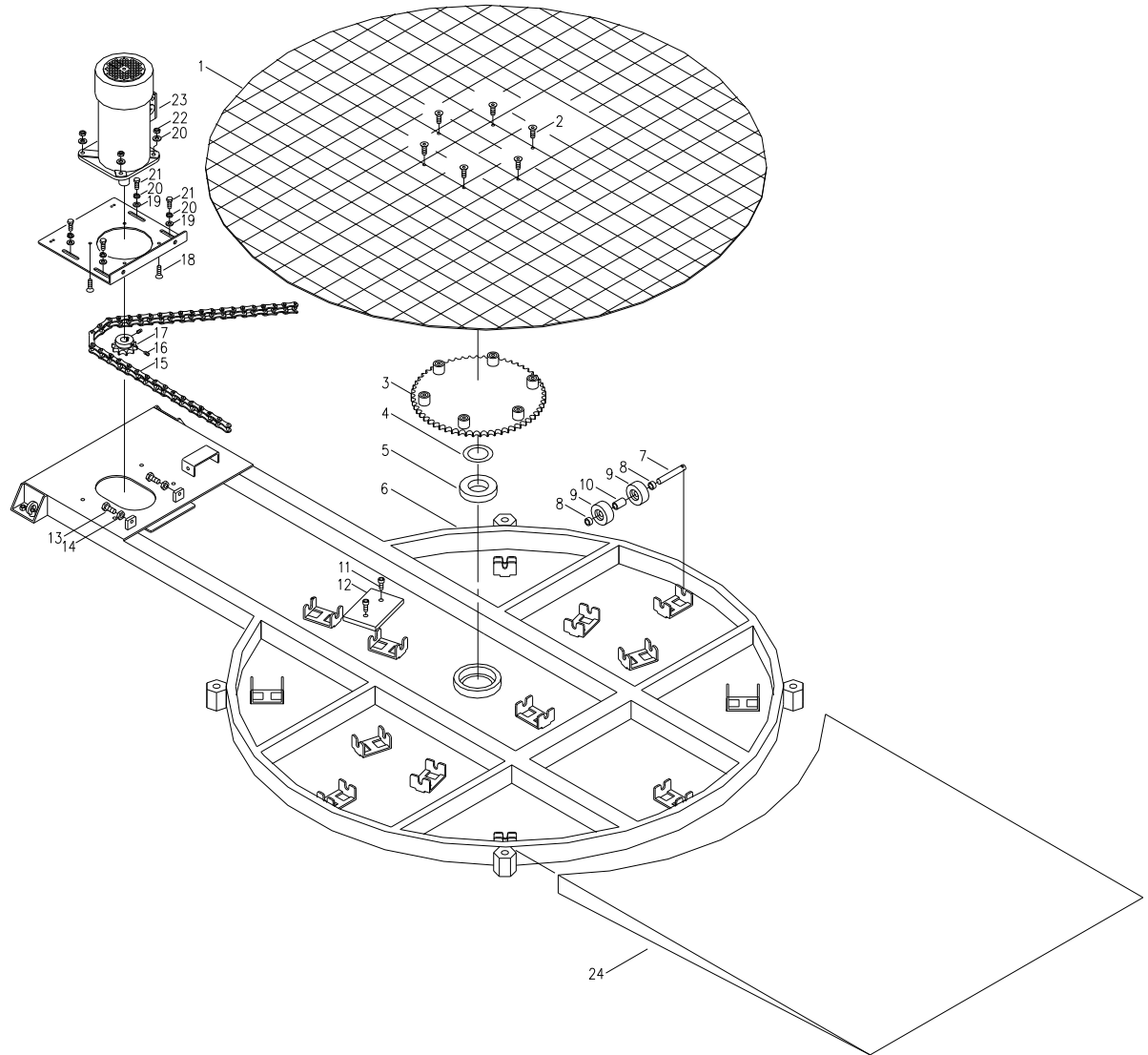

SPW-981 Pallet Wrapper Manual

Spare Parts List

Item #	Part #	Description	Qty.	
	1710-28	Chain Lube	1	
33	E29000	Limit Switch	1	
35	E41100	Fuse 8A	2	
9	B10043	Turntable support rollers	2	
20	B100113	Spring	1	
47	E28500	Limiter switch-turntable	1	
Total Cost				

SPW-981 Pallet Wrapper Manual

